

TECHNICAL SPECIFICATION

MODEL	OPENINGS	VOLUME (Ltrs.)	DOME VOLUME (Ltrs.)	DIMENSIONS (mm)					BASE	WEIGHT OF VESSEL WITH BASE (Kg)
				"D1"	"D"	"H" ± 25	"L"	"F"		
48X72	6" TOP AND BOTTOM	1746.3	533.0	1220	1180	2365	365	150	Tri-pod	165.8

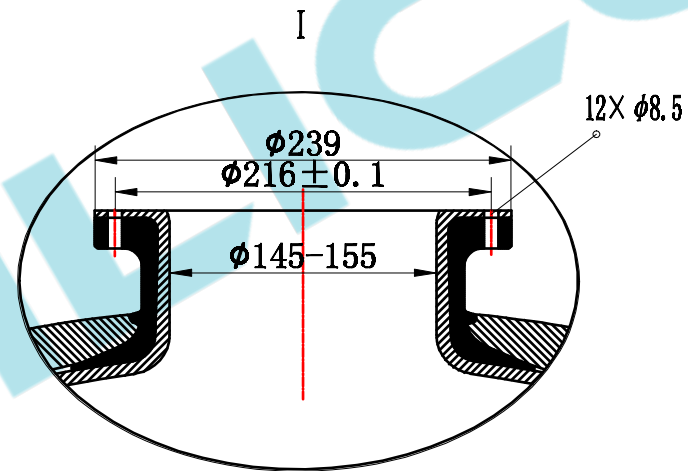

NOTES:

1. TANK MUST MEET ALL APPLICABLE SPECIFICATIONS OF NSF/ANSI 044 STANDARD, LATEST REVISION.

2. OPERATING SPECIFICATIONS:

- A. MAXIMUM WORKING PRESSURE: 10.5BAR(150PSI)
- B. TEMPERATURE RANGE: 1-50°C (34-122°F)
- C. MAXIMUM VACUUM: 17kpa (5" Hg)

SIGNATURE					
NAME	DATE				
DESIGN			SCALE 1: 8	MODEL: 48" (6" TOP AND BOTTOM)	
INSPECTION			QUANTITY	DESCRIPTION FRP	
APPROVAL				PRESSURE VESSEL	
THIS DRAWING CAN NOT BE COPIED AND/OR USED WITHOUT PRIOR WRITTEN APPROVAL OF NOYI			PROJECTION	COMPUTER CODE	VERSION NO.
				NY-TE-DR-SA-IEV-48	1.5
			DO NOT MEASURE THE DIMENSIONS.	UNIT: MM [] INCH	TOTAL PAGE: 1 OF 1